

* Certified:
**IGNITION
PROTECTED**



**2Year /
2000 Hour
Warranty**

**2.2 kW maximum power
1.9 kW continuous power**

The Mase Intercooler

The intercooler is cooled by water -- the engine is cooled by air. This unique Mase time-tested design creates an internal circular motion of air keeping the engine, as well as the alternator, at the ideal temperature. By creating this cooling "capsule" a minimal amount of heat is absorbed and emitted by the genset.

Engine

Model:	Yanmar L48AE
Type:	Diesel / 4-stroke
Cylinders:	1
Cylinder block material:	Aluminium
Bore:	2.75"
Stroke:	2.16"
Displacement :	211cc
Power @ 3600rpm:	4.7hp
RPM:	3600
Compression ratio:	20.5:1
Combustion system:	Direct injection
Engine head material:	Aluminium
Speed governor:	Centrifugal mechanical
Lubrication system:	Forced
Oil sump capacity with filter:	0.85qt.
Engine stop system:	Fuel solenoid
Fuel pump:	Electric
Fuel pump discharge:	2.3'
Fuel consump. @ full load:	.211 gal/hr
Air combustion requirement:	12cfm
Starting battery:	45Ah - 12V
Starter:	0.8kW - 12V
Max. inclination:	30°
Water pump flow:	4.4gal/min

Genset Model # IS2.5

Remote Control Panel (standard with genset)

- A compact 5-3/8" x 3-5/8" with a 33' shielded cable
- The microprocessor based design features a vibration-proof keypad with UV protection.
- Digital hour-meter
- ON/START/OFF controls
- Low oil pressure light
- Engine and alternator high temperature warning lights and safety cut-outs

Engine

- One-side serviceability of injection and lubrication system, sea water pump and air filter
- Low oil pressure safety cut-out
- Exhaust high temperature safety cut-out
- Vibration damping mounts
- Oil sump evacuation pump included with genset

Alternator

- Synchronous, 2 poles, self-excited
- Rotor and stator epoxy resin coated against external agents
- Rotor dynamically balanced
- Insulation class H

Sound absorbant exterior housing

Manufactured with ABS material, the housing provides effective sound reduction and ensures the proper operation of the inter-cooler system. These panels are removable, offering easy access during installation, and maintenance, even in very tight areas. The exterior housing of the IS2.5 offers practical, quiet function with size efficiency.

Generator Ratings

Type:	Brushless, synchronous, 2-poles, self-excited
Cooling:	Air/water (Intercooler water/air)
Voltage:	120 - 240V
Nominal current:	18.3 - 9.16A
Frequency :	60Hz
Max. power :	2.2kW
Continuous power:	1.9kW
Battery charging output:	10A - 12V
Power factor (cos ϕ):	1
Insulating class:	H
Voltage stability:	$\pm 10\%$
Frequency stability:	$\pm 5\%$

Engine cooling system

The engine cooling system is based on a raw water/air heat exchanger which reduces the temperature of the air flow inside the box. The system also cools the alternator providing the optimal temperature for the best performance and reliability of the genset, regardless of its on-board location.

Dimensions: (LxWxH) 20" x 15-3/4" x 18-1/4"
Weight: 143 lbs.
Sound Level: 56 dBA at 23' (7m)

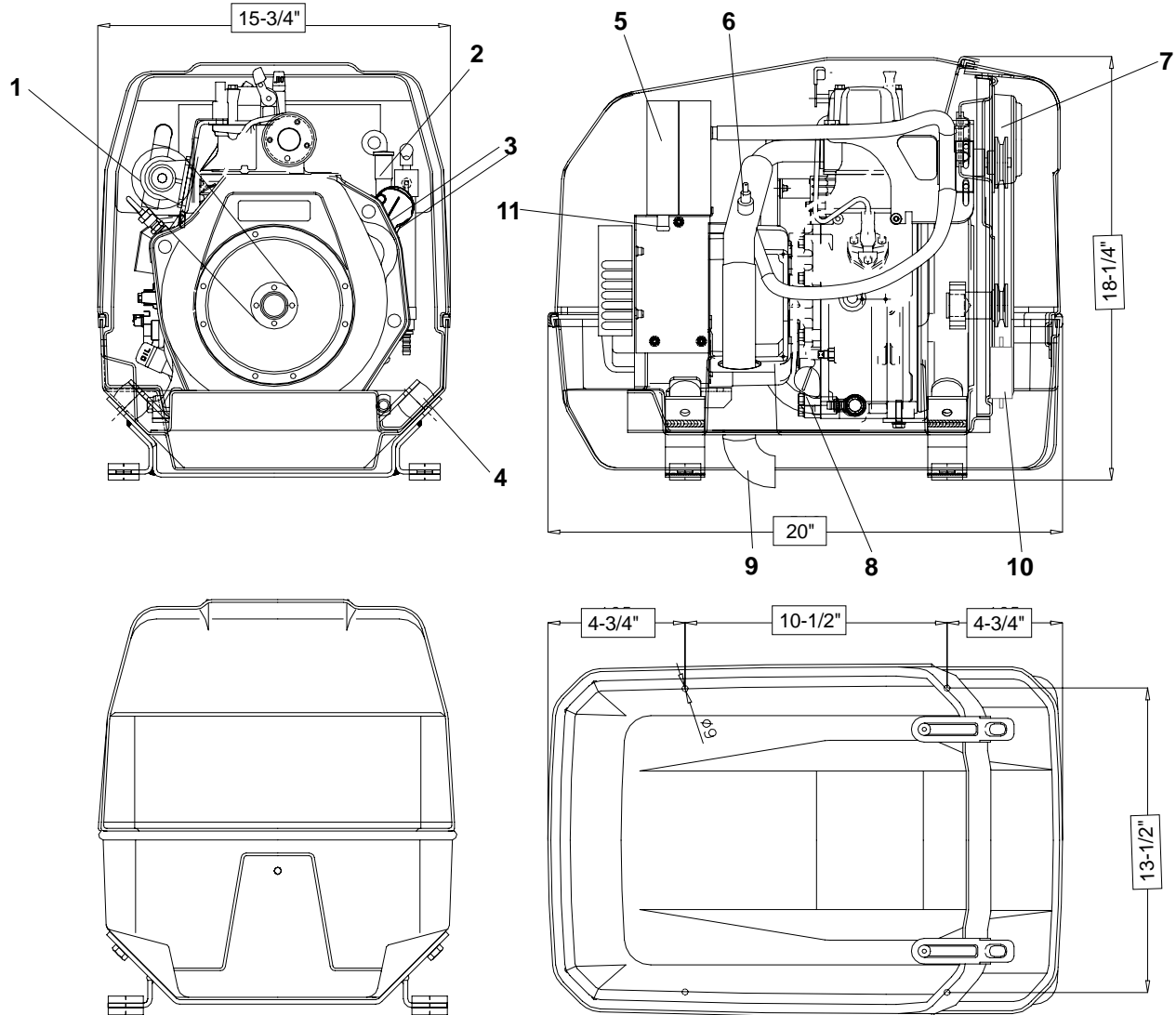

Suggested Installation Accessories

- **Exhaust Kit** - reduces sound of engine exhaust
- **Water/Gas Separator Kit** - separates water and exhaust while further reducing sound
- **Siphon Break** - prevents sea water from entering the generator when off... *mandatory for below waterline installations*

- 1- Raw water pump
- 2- Oil fill cap
- 3- Starter
- 4- Vibration mounts
- 5- Heat exchanger (Intercooler water/air)
- 6- Exhaust temperature sensor
- 7- Air cleaner
- 8- Oil filter
- 9- Exhaust mixer (1-3/4")
- 10- Fuel pump connection (1/4")
- 11- Connection to raw water intake (5/8")

Mase Generators S.p.A. and Mase Generators North America reserve the right to change the design or specifications without notice and without any obligation or liability whatsoever.